

Type of article

# Design of UWB Microstrip Antenna with Frequency Notch Characteristics

ShahadevHake<sup>1</sup>, ShirgureSonali<sup>2</sup>, Satpute Priyanka<sup>3</sup>

<sup>1</sup> Professor, Pune Institute Of Computer Technology, Pune.

<sup>2,3</sup> Students, Pune Institute Of Computer Technology, Pune.

**Abstract** - A square Ultra-wideband (UWB) antenna with band-notched characteristics is proposed using U-shaped slots on radiating patch is designed. The proposed design uses a U-shaped slot on radiating microstrip patch antenna. In this design, microstrip fed is utilized along with a partial ground plane. This antenna may be utilized for frequencies ranging from 3 to 10.6 GHz, with band notching ranging from 5.1 GHz to 5.8GHz. This antenna may be utilized for applications in ITU uplink satellite communication band (8.1-8.4 GHz), Xband for satellite communication( 7.25 to 7.75GHz), and Super extended C band(5.8 to 6.725 GHz) while rejecting 5.1 to 5.8 GHz WLAN band.

**Keywords** - Square ultra-wideband antenna, partial ground plane, band notch characteristic, WLAN.

## I. INTRODUCTION

Wireless communication is the most popular technology for long-distance communication, and researchers have shown very interest in improving various parameters in long and short-distance communications. After the Federal Communication Commission (FCC) declaration in 2002 as Ultra-Wide Band (UWB) from 3.10 to 10.60 GHz unlicensed band for commercial use, it attracted the interest of scholars from academics and industries for future short distance communications. Microstrip antennas are auspicious for design UWB antennas. Presently available UWB devices are highly affected by enormous electromagnetic interferences due to the other existing narrowband wireless communication systems like WiMAX applications in the 3.30–3.60 GHz band and WLAN systems in the 5.10–5.80 GHz band. So, to suppress the discussed interferences due to existing narrowband communication systems, it is essential to make antennas with filtering attributes. Recently some distinct approaches like slot etching on the radiating surface or ground surface, folded strips, tuning stubs, meandering, and EBG configurations have been suggested in the literature to make band-notched UWB

antenna. We are using slot etching on radiating patch method for rejecting the WLAN band. Inserting the proper dimension U slot on the patch of an antenna creates a notch at the desired frequency band.

## II. ANTENNA DESIGN AND CONFIGURATION

Deschamps first proposed the idea of the microstrip antenna in 1953 and a patent in 1955. However, the first antenna was developed and fabricated during the 1970s when good substrates became available. A microstrip antenna is also referred to as a patch antenna. Microstrip patch antenna consists of a radiating patch on one side of a dielectric substrate and a ground plane on the other side. The patch is generally made of a conducting material such as copper or gold and can take any possible shape. Several shapes can be used as the radiating patch. The radiating patch may be square, rectangular, thin strip (dipole), circular, elliptical, triangular, or a combination.

### A. Design Procedure

Using the design specifications along with the equations obtained from the transmission line model of analysis, the dimensions of the microstrip patch antenna can be calculated as explained below:

Step 1: For efficient radiation, the width is given as:

$$W = c / (2f_0 \sqrt{(\epsilon_r + 1)/2})$$

Step 2: Calculation of effective dielectric constant.

$$\epsilon_{\text{reff}} = ((\epsilon_{\text{reff}} + 1)/2) + [((\epsilon_{\text{reff}} - 1)/2) (1 + 12 h/W)^{-1/2}]$$

Step 3: Calculation of effective length of the patch:

$$L_{\text{eff}} = c / (2f_0 \sqrt{\epsilon_{\text{reff}}})$$

Step 4: Calculation of length extension:

$$\Delta L = 0.412h [((\epsilon_{\text{reff}} + 0.3)(W/h + 0.264)) / ((\epsilon_{\text{reff}} - 0.258)(W/h + 0.8))]$$

Step 5: Calculation of Length:

$$L = \frac{c}{2fr\sqrt{\epsilon_{\text{reff}}}} - 2\Delta L$$

Step 6: Calculation of ground plane dimensions:

The transmission line model applies to infinite ground planes only. However, it is essential to have a finite ground plane for practical considerations. It has been shown that similar results for the finite and infinite



ground plane can be obtained if the size of the ground plane is greater than the patch dimensions by approximately six times the substrate thickness all around the periphery. This step increases the bandwidth of the antenna.

Step7:Insert U slot inside the patch of an antenna which creates a notch at the desired frequency.

**Table 1. Design parameters of patch antenna**

Parameters	Values
Input Impedance( $Z_0$ )	50Ω
Frequency( $F_0$ )	5.7GHz
Dielectric Constant( $\epsilon_r$ )	4.4
Height of substrate(H)	1.6mm

**Table 2. Calculated parameters for patch**

Parameters	Values
Patch Width ( $W_p$ )	12mm
Patch Length( $L_p$ )	12mm
Dielectric Constant( $\epsilon_{reff}$ )	4.03

**Table 3. Calculated parameters for the line**

Parameters	Values
Line Width ( $W_l$ )	2.9mm
Line Length( $L_l$ )	7.2mm

**Table 4. Antenna design and parameters dimensions**

Parameters	Value(mm)
Width of substrate	27.7mm
Length of Substrate	30mm
Outer slot width	8mm
Outer slot Length	6mm
Defected Ground Length	7.2mm
Slot in defected ground	3mm*3.3mm
Ground corner cut	3.8mm*3.8mm

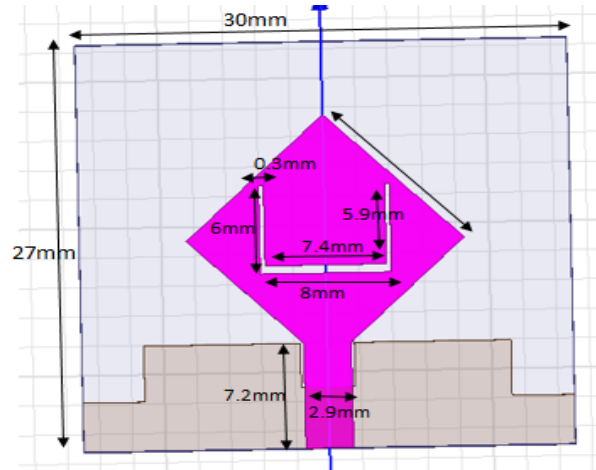

**Fig. 1 Dimensions of the proposed antenna**

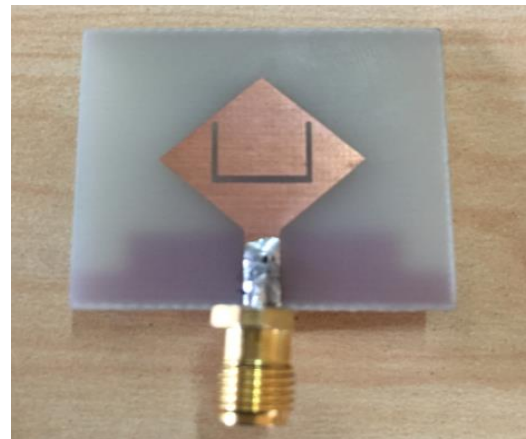

**Fig. 2 Front view of the fabricated antenna**

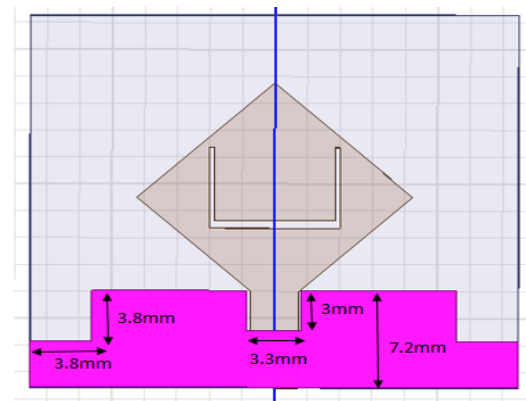

**Fig. 3 The modified ground of the simulated antenna**

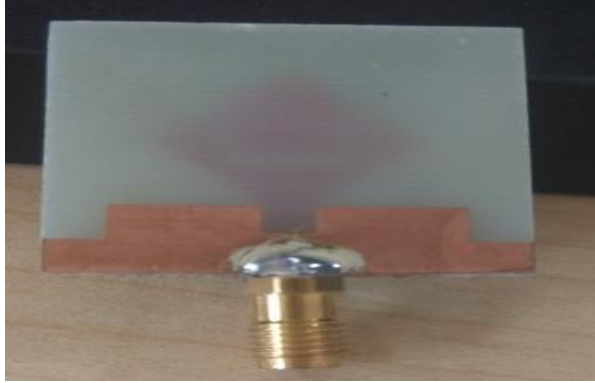

Fig. 4 The modified ground of the fabricated antenna

### III. RESULT AND DISCUSSION

#### A. Return loss

It is a parameter that indicates the amount of power "lost" to the load and does not return. Hence the RL is a parameter to indicate how well the matching between the transmitter and antenna has taken place. Put it is the S11 of an antenna. A graph of s11 of an antenna VS frequency is called its return loss curve. For optimum working, such a graph must show a dip at the operating frequency and have a minimum dB value.

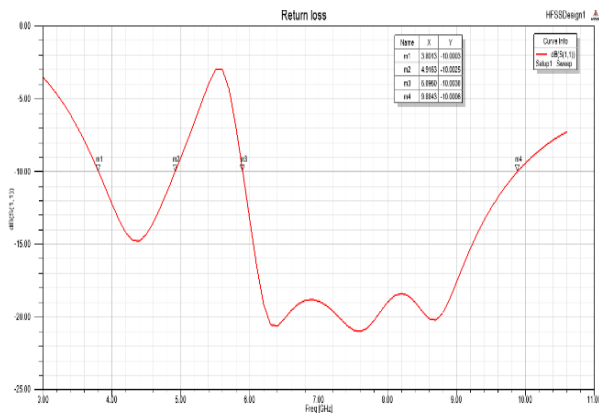

Fig. 5 Simulated return loss VS frequency

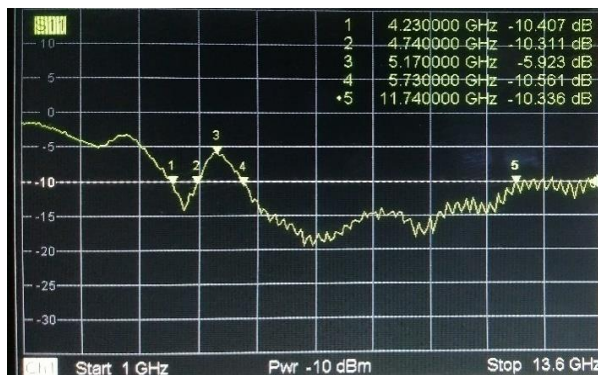

Fig. 6 Actual return loss VS frequency

Fig.5. shows simulated results of return loss. As shown in the figure, we get a notch at 5.1 to 5.8GHz, which gives a return loss of -14.73dB with a bandwidth 1.11MHz (3.8 to 4.91 GHz), and the second band gives a return loss of -20.5dB of with bandwidth 4MHz(5.89 to 9.88 GHz).Fig.6.shows the actual return loss. The figure shows that we get a notch at 4.7 to 5.7GHz.

#### B. VSWR

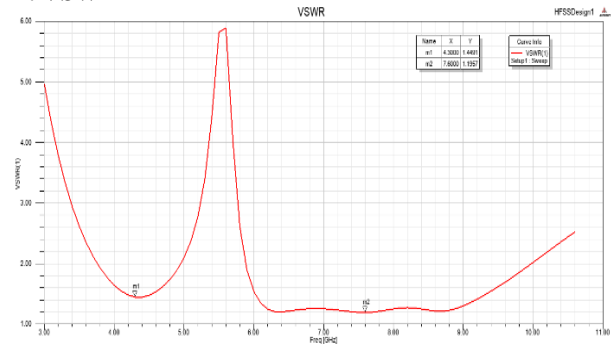

Fig. 7 Simulated voltage standing wave ratio

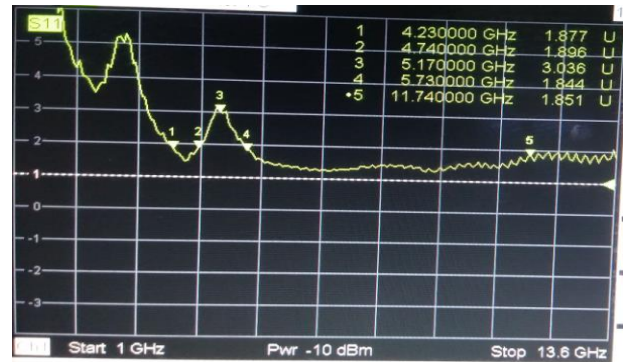

Fig. 8 Actual voltage standing wave ratio

Fig.7.shows simulated results of VSWR, as shown in fig. We get two bands. For the first band, VSWR is 1.44, and for the second band, VSWR is 1.26. Fig. 8 shows the actual VSWR below 2 for frequency 4.2-11.7GHz. The measured value below 2 shows that the antenna is transmitting more than 70 percent of its received power, and if it is above, the antenna will transmit less than 70 percent of its received power.

#### C. Radiation pattern

A radiation pattern is defined as the power radiated or received by an antenna based on the angular position and radial distance from the antenna. It describes how the antenna directs the energy it radiates.

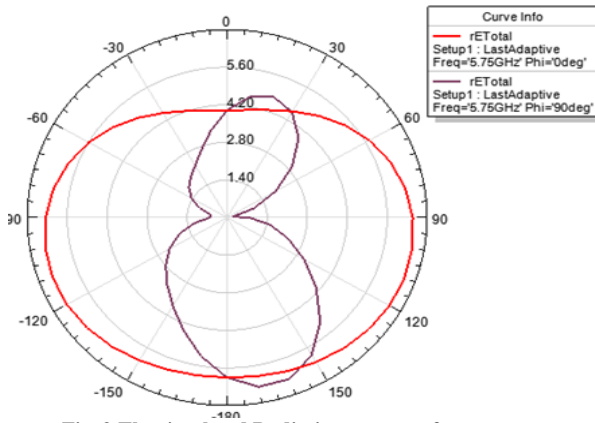

Fig. 9 The simulated Radiation pattern of an antenna

Fig.9. shows radiation pattern is nearer to figure of eight for E plane and omnidirectional in H plane. The polarization of the proposed antenna is linearly polarized. The radiation pattern is maximum to perpendicular to the patch of the antenna.

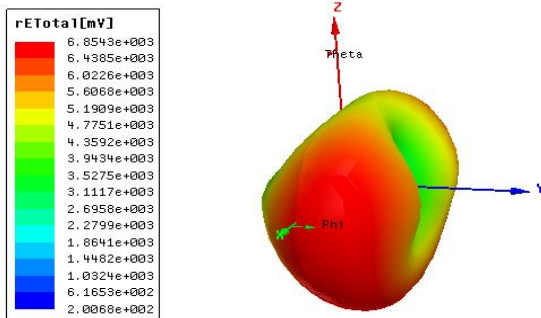

Fig.10 Simulated 3D polar plot of an antenna current density

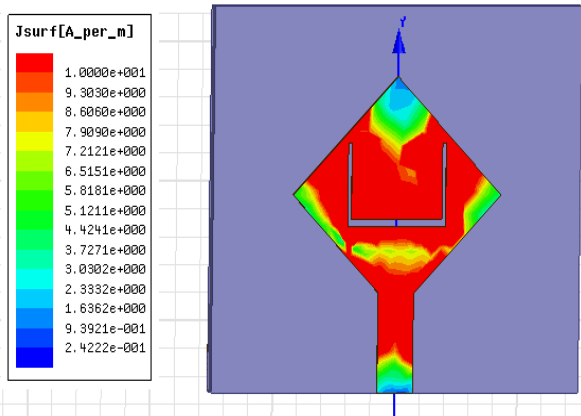

Fig. 11 Simulated surface current density on patch.

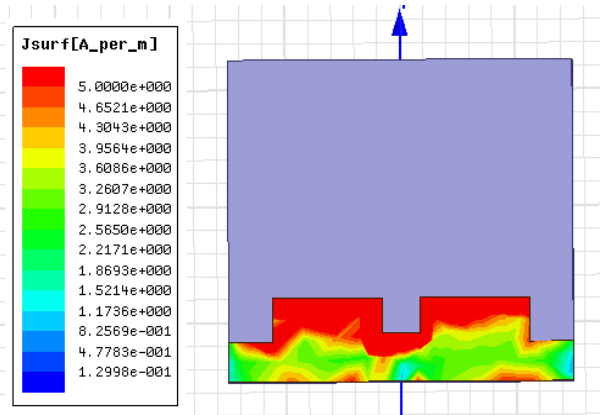

Fig. 12 Simulated surface current density on the ground plane

Fig.11 shows the current density for the patch, and it can be observed that the current density is high at the center of the patch. Fig.12 shows the current density for the modified ground structure, which is high at the upper edges.

Table 5. Different Antenna parameters

Quantity	Value
Incident Power	1(W)
Radiated Power	0.419339(W)
Accepted Power	0.72593(W)
Max U	0.06231(W/sr)

#### IV. CONCLUSION

We studied and analyzed different antenna parameters from this work conducted on microstrip patch antenna for ultra-wideband with notch characteristics. This project demonstrates an Ultra-wideband (UWB) antenna with band-notched characteristics with the help of U-shaped slots on the radiating patch and modified ground. The size of every parameter used for designing and optimizing the antenna was used for better return loss curve and ultra-wideband operations. U-shaped slots with ground-modified antenna make well suited for UWB applications while rejecting the desired band(5.1 to 5.8 GHz). The antenna may be used for applications in ITU uplink satellite communication band (8.1-8.4GHz), X band for satellite (7.25 to7.75GHz), and Super extended C band(5.8 to 6.7GHz) while rejecting 5.1 to 5.8 GHz WLAN band.

## REFERENCES

- [1] Shweta Agarwal, Ajay Yadav, and R.P. Yadav, "A Compact Triple Band Notched UWB antenna: SRR and Feed Miniaturization" Dept. Of ECE, Global institute of technology Jaipur, IEEE WISPNET 2017Conference.
- [2] Constantine A. Balanis, Antenna Theory: Analysis and Design, 2nd Edition; John Wiley Sons Inc. New York,2001,pp12-130
- [3] M.I. Nawaz et al., "A Review on Wideband Microstrip Patch Antenna Design Techniques "Design Techniques" in International Conference on Aerospace Science & Engineering (ICASE),2003
- [4] S.-W. Qu, J. L. Li, and Q. Xue, "A band-notched ultra wideband printed monopole antenna," IEEE Antennas Wireless Propag Lett., vol.5.
- [5] J. Y. Siddiqui, C. Saha, and Yahia M. M. Antar, "Compact SRR loaded UWB circular monopole antenna with frequency notch characteristics,"IEEE Trans. on Antennas and Propag., vol. 62.
- [6] "Microstrip antenna and its application. Available: [www.electronicsforu.com](http://www.electronicsforu.com)
- [7] Singh, A. Arya, and S. Sharma, "High Gain of C Shape Slotted Microstrip Patch Antenna for Wireless System Abstract ;," International Journal of Applied Engineering Research, vol. 7, no. 11, pp.11–1
- [8]